

## 8300/8305/LICS Series

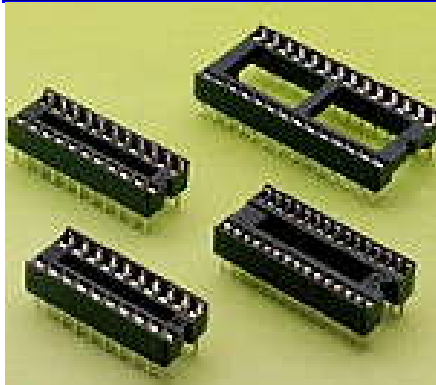

### Features

#### ◆ 8300 Socket:

- Low profile
- Dual contact terminal
- Available in 6,8,14,16,18,20,22,24,28,32,40, 42 and 48 circuits
- Glass filled polyester UL94V-0 PBT
- Anti solder wicking
- Contact: Phosphor bronze
- Plating: Tin plated

#### ◆ 8305 Socket:

- Low profile
- Dual contact terminal
- Available in 16,20,22,24,28,30,32,40,42,48,52,56 and 64 circuits
- Glass filled polyester UL94V-0 PBT
- Anti solder wicking
- Contact: Phosphor bronze
- Tin plated contact as standard
- Saving on P.C.B. real estate
- Manually and automatically insertable

#### ◆ LICS Socket:

- Low profile
- Available in 20,22,24,28 and 32 circuits
- Glass filled polyester UL94V-0 PBT
- Contact: Phosphor bronze
- Plating: Tin plated

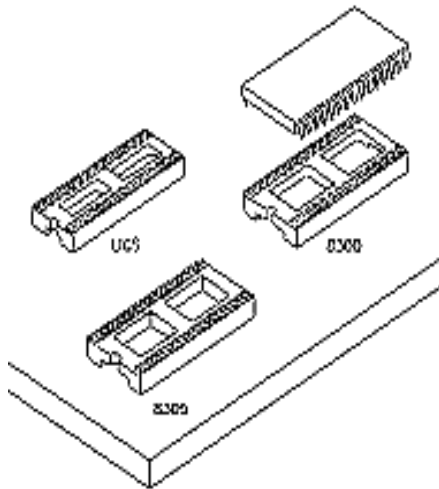

### Specifications

- ◆ Current rating: 1A AC,DC
- ◆ Voltage rating: 250V AC,DC
- ◆ Temperature rating: -40°C ~ +105°C
- ◆ Contact resistance:
  - Initial: 20mΩ max.
  - After environmental test: 40mΩ max.
- ◆ Insulation resistance:
  - Initial: 1,000MΩ min.
  - After humidity and thermal shock test: 500MΩ min
- ◆ Withstanding voltage: 1,000V AC /minute
- ◆ Applicable PC board thickness: 1.6mm

### Standards

 Recognized No. E82349(8300)

Ordering Information :

8300 - \*\* AT00  
I

Unit:  $\frac{\text{mm}}{\text{inch}}$

I. No. of circuits

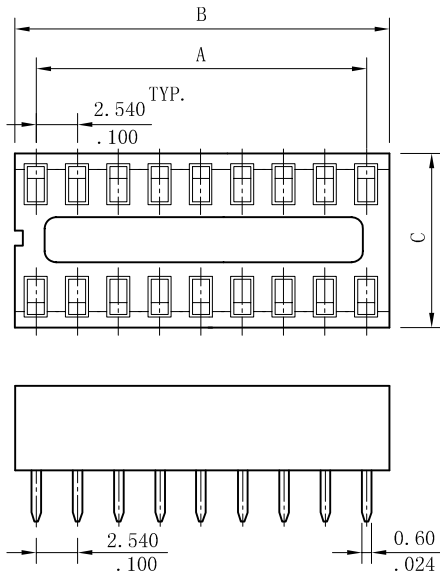

TYPICAL 6, 8, 14, 16, 18, 20, 22 CIRCUITS

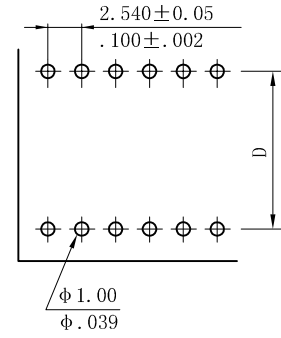

RECOMMENDED HOLE PATTERN

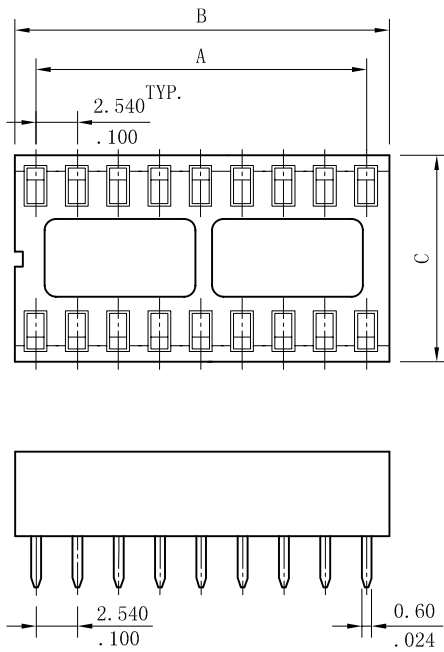

TYPICAL 24, 28, 32, 40, 42, 48 CIRCUITS

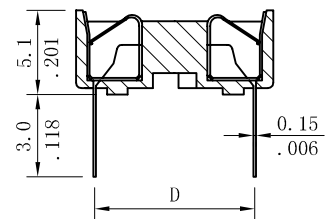

Part No.	Dim. A	Dim. B	Dim. C	Dim. D
8300-06AT00	5.080 (.200)	7.62 (.300)	10.0 (.394)	7.62 (.300)
8300-08AT00	7.620 (.300)	10.16 (.400)	10.0 (.394)	7.62 (.300)
8300-14AT00	15.240 (.600)	17.78 (.700)	10.0 (.394)	7.62 (.300)
8300-16AT00	17.780 (.700)	20.32 (.800)	10.0 (.394)	7.62 (.300)
8300-18AT00	20.320 (.800)	22.86 (.900)	10.0 (.394)	7.62 (.300)
8300-20AT00	22.860 (.900)	25.40 (1.000)	10.0 (.394)	7.62 (.300)
8300-22AT00	25.400 (1.000)	27.94 (1.100)	10.0 (.394)	7.62 (.300)
8300-24AT00	27.940 (1.100)	30.48 (1.200)	17.7 (.697)	15.24 (.600)
8300-28AT00	33.020 (1.300)	35.56 (1.400)	17.7 (.697)	15.24 (.600)
8300-32AT00	38.100 (1.500)	40.64 (1.600)	17.7 (.697)	15.24 (.600)
8300-40AT00	48.260 (1.900)	50.80 (2.000)	17.7 (.697)	15.24 (.600)
8300-42AT00	50.800 (2.000)	53.34 (2.100)	17.7 (.697)	15.24 (.600)
8300-48AT00	58.420 (2.300)	60.96 (2.400)	17.7 (.697)	15.24 (.600)

$A = 1.778\text{mm}(.070'') * \text{No. of Spaces}$   
 $B = A + 1.778\text{mm}(.070'')$   
 $C = 7.620\text{mm}(.300'')$  (16~22 circuits)  
 10.160mm(.400'') (24~32 circuits)  
 15.240mm(.600'') (40~56 circuits)  
 19.050mm(.750'') (64 circuits)  
 $D = 10.1\text{mm}(.398'')$  (16~22 circuits)  
 12.6mm(.496'') (24~32 circuits)  
 17.7mm(.697'') (40~56 circuits)  
 21.5mm(.846'') (64 circuits)

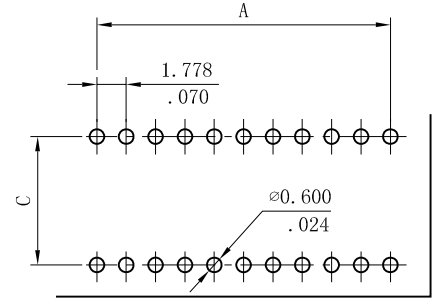
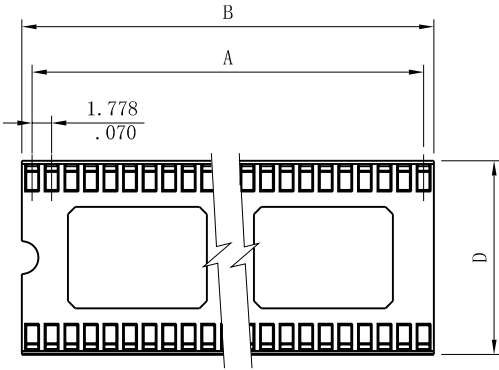

RECOMMENDED HOLE PATTERN

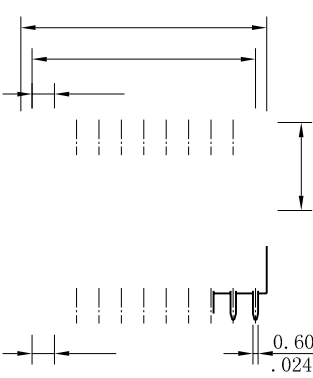
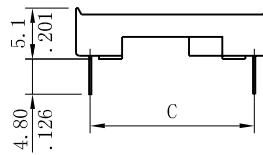
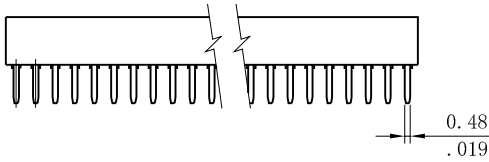

TYPICAL 22 CIRCUITS

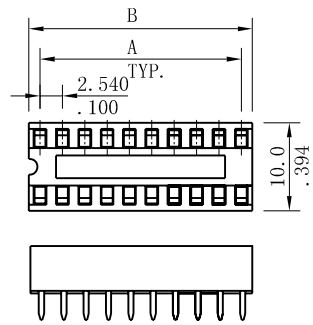

TYPICAL 20 CIRCUITS

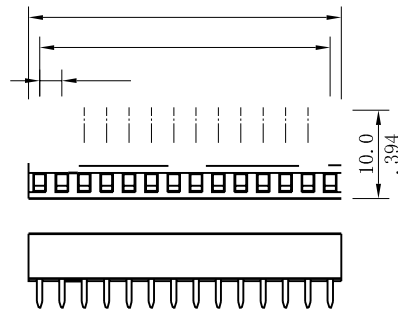

TYPICAL 24, 28, 32 CIRCUITS

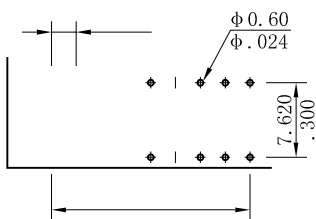
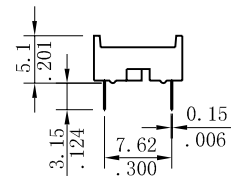

Circuits	P/N	Dim A	Dim B
20	LICS-20AT00	22.86 (.900)	25.4 (1.000)
22	~22AT00	25.40 (1.000)	27.9 (1.098)
24		27.94 (1.100)	30.3 (1.193)
28		33.02 (1.300)	35.6 (1.402)
32		38.10 (1.500)	40.5 (1.594)